

ČVUT v Praze, Fakulta strojní

Ústav technologie obrábění, projektování a metrologie

Výrobní postup - zadání

# SEMINÁŘ Z TECHNOLOGIE II.



# Výkres č. 1

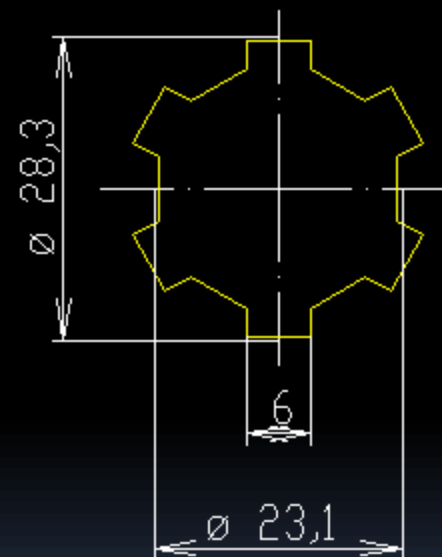
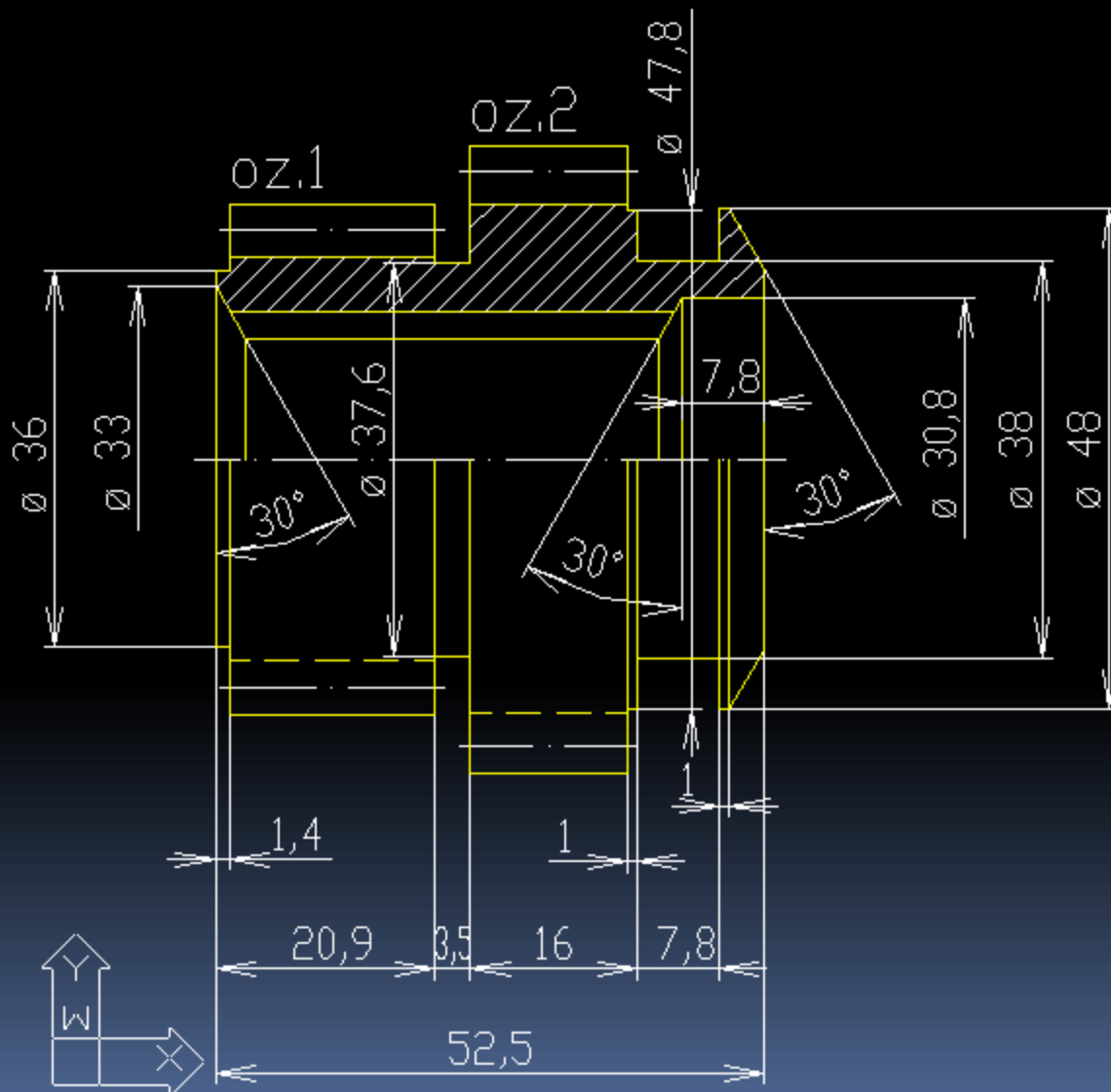

# Výkres č. 2

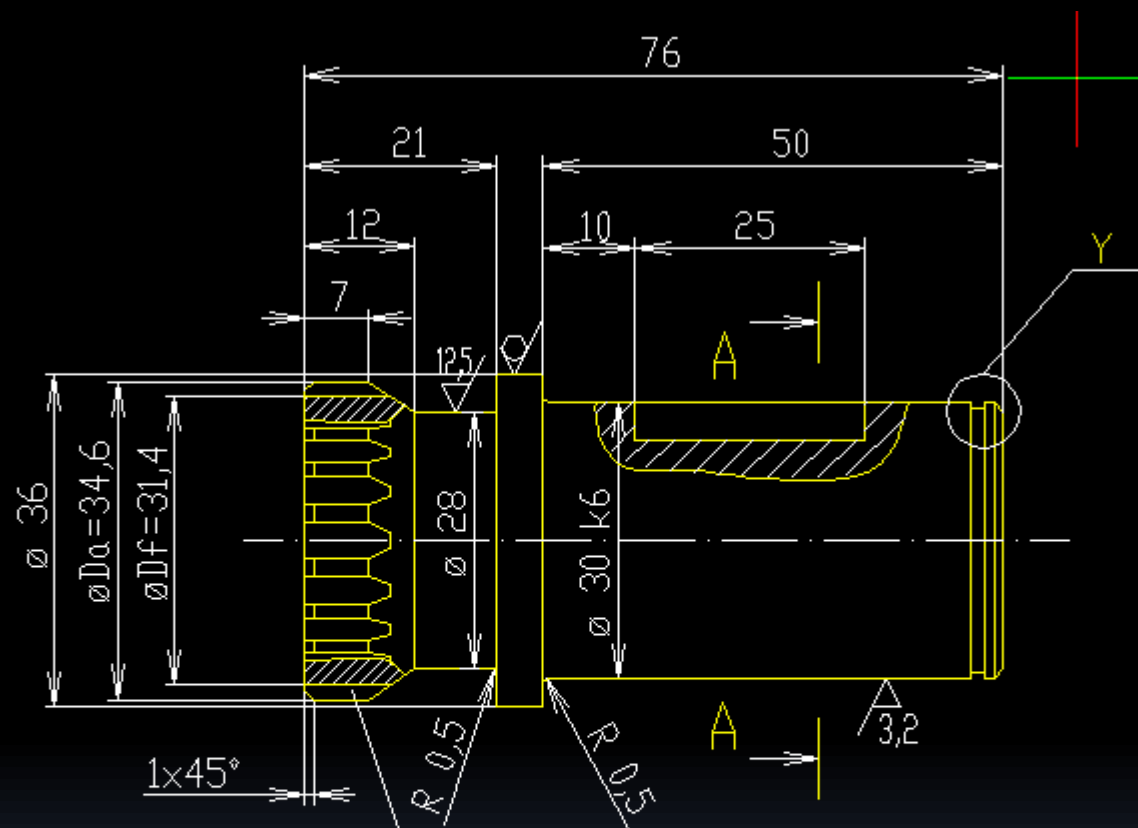

Drážkování 35x1,5 h9 (z=22)

ČSN 01 4950.1

# Výkres č. 3

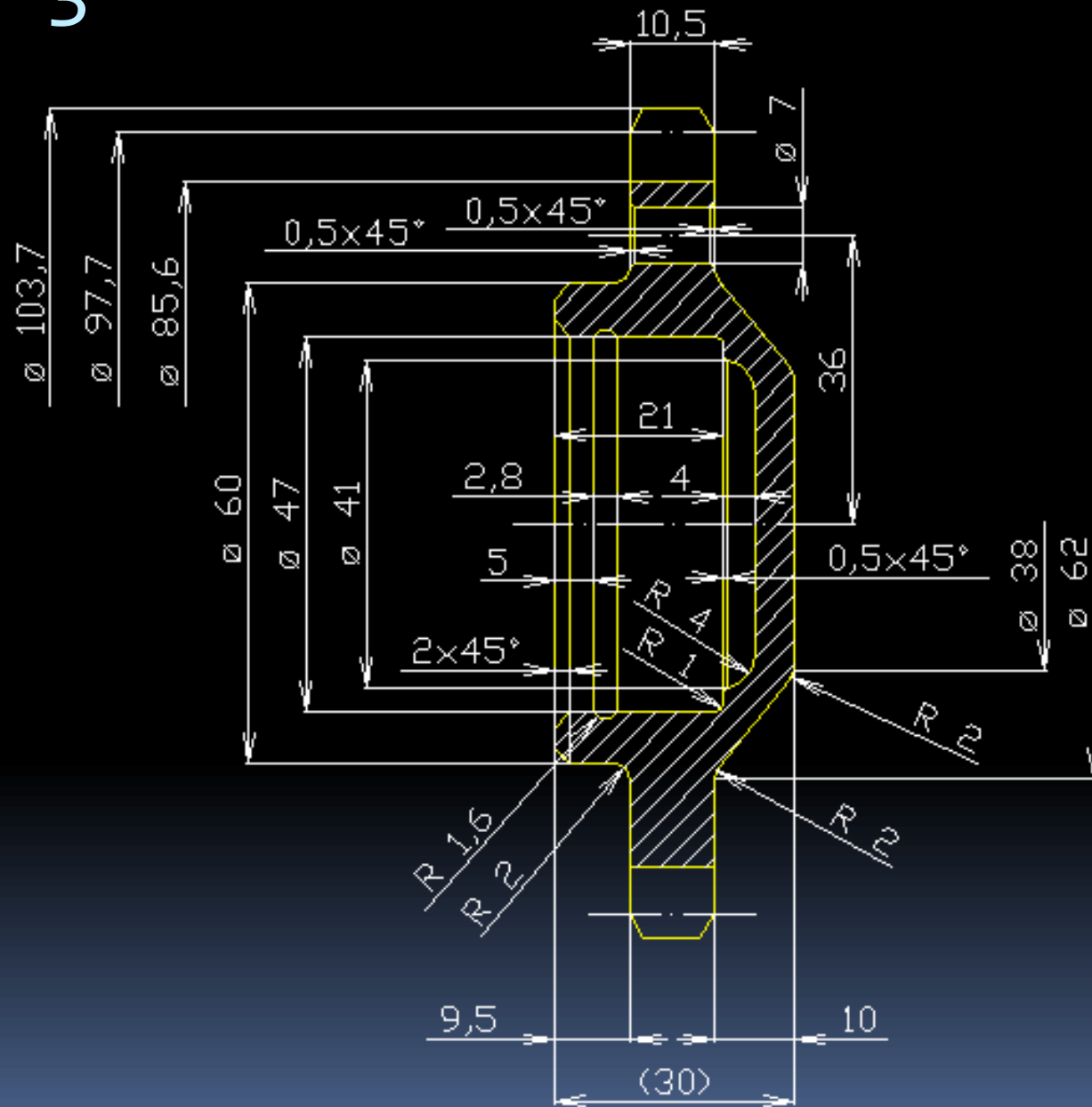

# Výkres č. 4

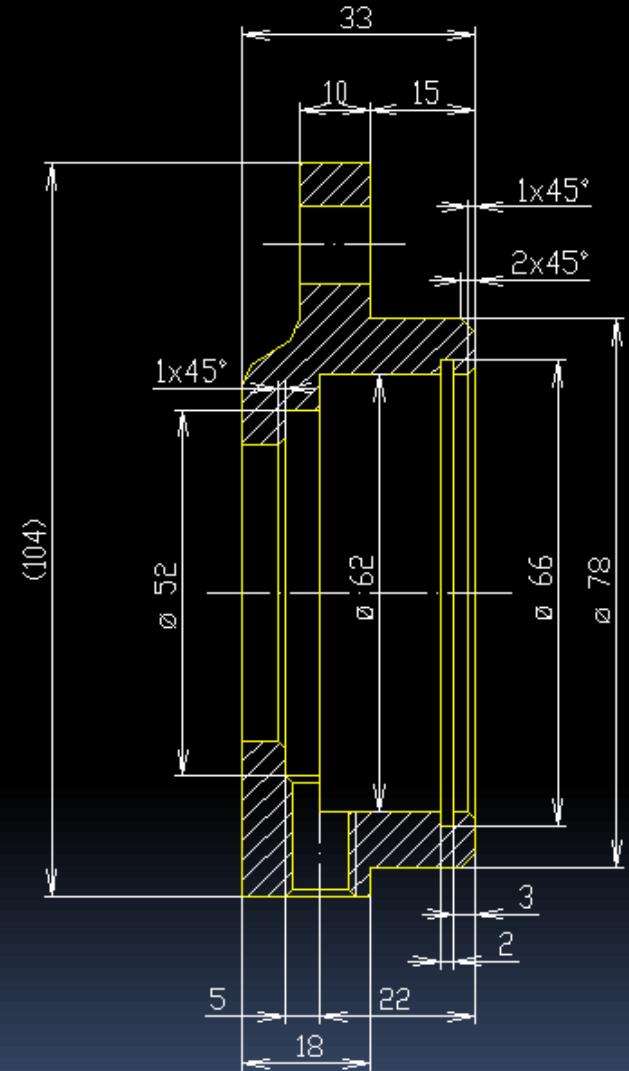

# Výkres č. 5

6,3/3/0

cementovat do hl.0,5mm na HRC 50-2+  
nitridovat do hl.0,45mm na HV 657

Z (2:1)

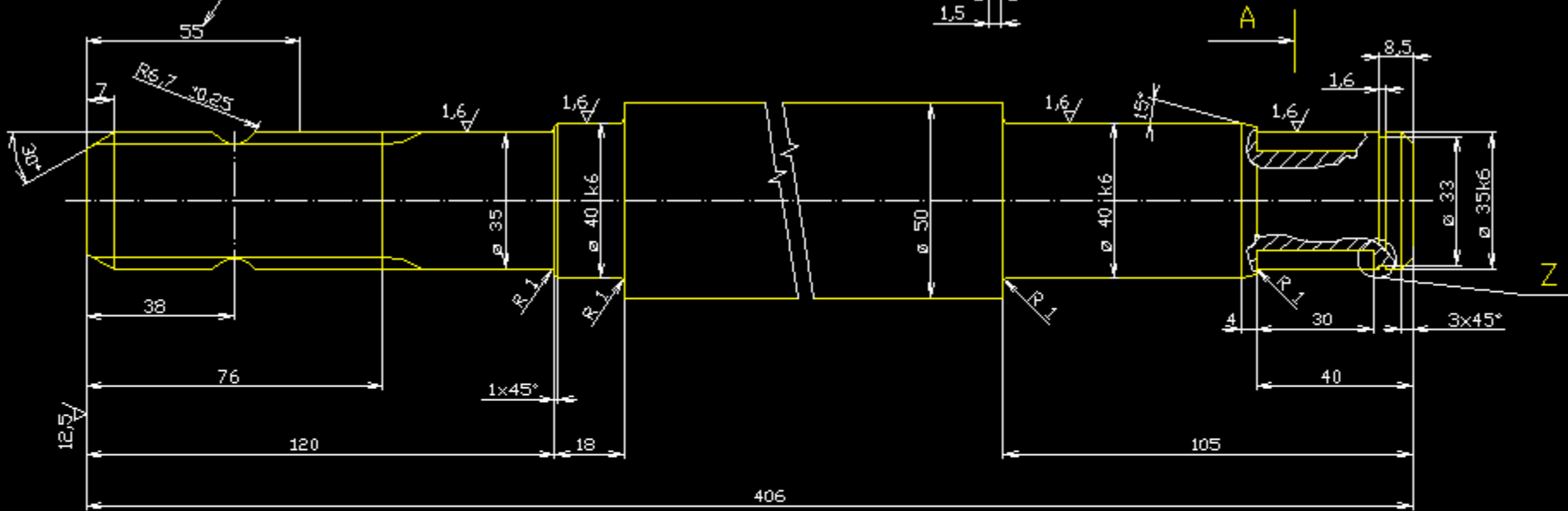
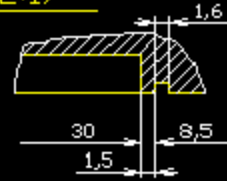

A-A

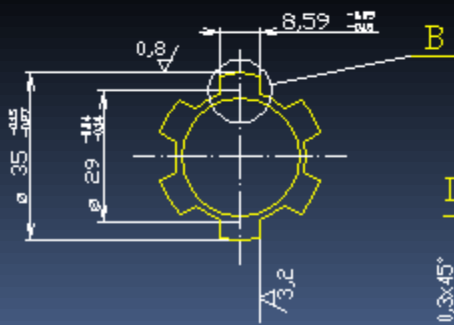

DET. B

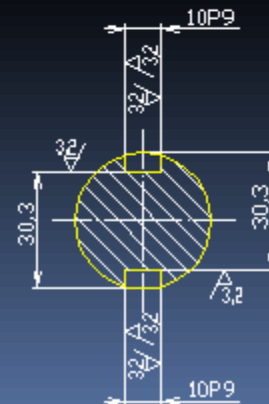
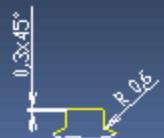

# Výkres č. 6

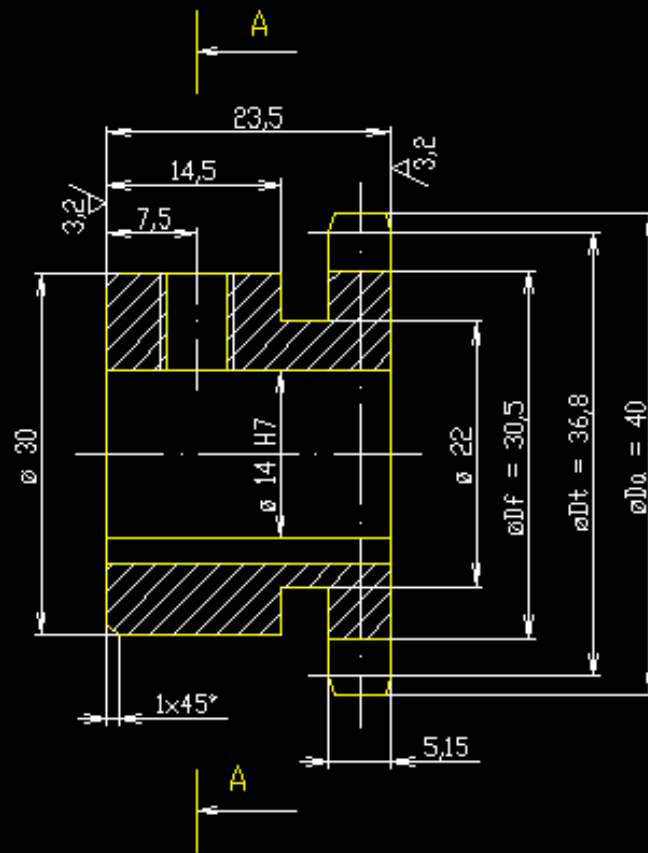

$6,3 \sqrt{\text{A}}$  ( $3,2 \sqrt{\text{A}}$ )

Řetěz 06B	
t	9,525
z	12
b1	5,72
d1	6,35

